

RECOMMENDED PCB LAYOUT
(TOP VIEW)

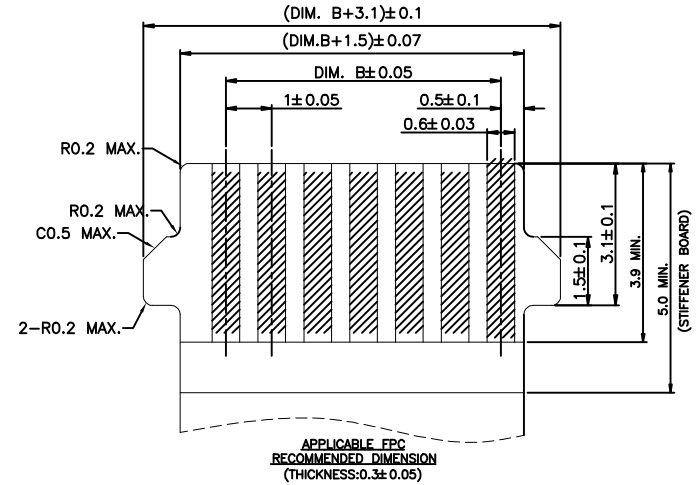

NOTES:

- MATERIAL:
 - HOUSING: THERMOPLASTIC, HIGH TEMP.,UL94V-0; COLOR:NATURAL.
 - CONTACT: COPPER ALLOY
 - FITTING NAIL: COPPER ALLOY
 - ACTUATOR: THERMOPLASTIC, HIGH TEMP.,UL94V-0; COLOR:BLACK.
 - FINISH:
 - CONTACT:
 - 50~100u" NICKEL UNDERPLATING OVERALL.
 - 1: GOLD FLASH PLATING.
 - ACTUATOR:
 - 50~100u" NICKEL UNDERPLATING OVERALL.
 - 1: GOLD FLASH PLATING.
 - REFLOW SOLDER CAPABLE TO 260°C PER ACES SPEC.
 - SPEC. PLS. REFER TO PS-50523-XXXX
 - PACKAGE PLS. REFER TO 91509-XXXX-TRP
 - PART NUMBER
50692-XXX X X-001
- NO OF CKT _____ PLATING
 1: G/F OVERALL(LEAD FREE)
 A: 3u" GOLD ON CONTACT AND SOLDER FOR GOLD FLASH PLATING
 0:TAPE & REEL
 1:TUBE
 4:TAPE & REEL WITH MYLAR
 5:TUBE WITH MYLAR
 C: 15u" GOLD ON CONTACT AND SOLDER FOR GOLD FLASH PLATING
 S: 15u" GOLD ON CONTACT AND SOLDER FOR 1u" GOLD PLATING ON SOLDER TAIL
 P: 3u" GOLD ON CONTACT AND SOLDER FOR 1u" GOLD PLATING ON SOLDER TAIL

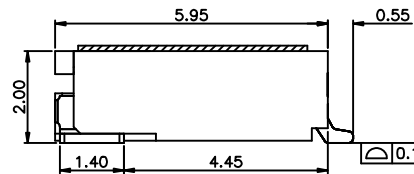
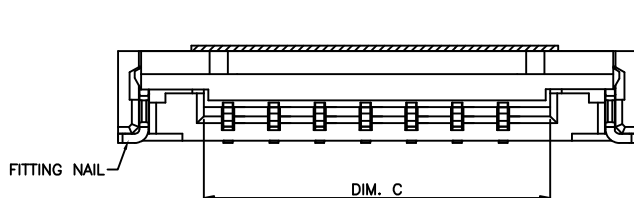
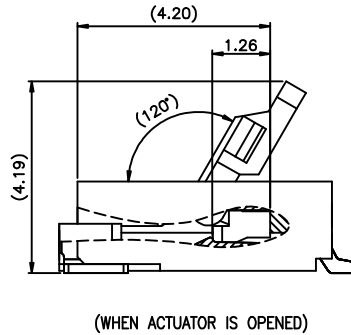
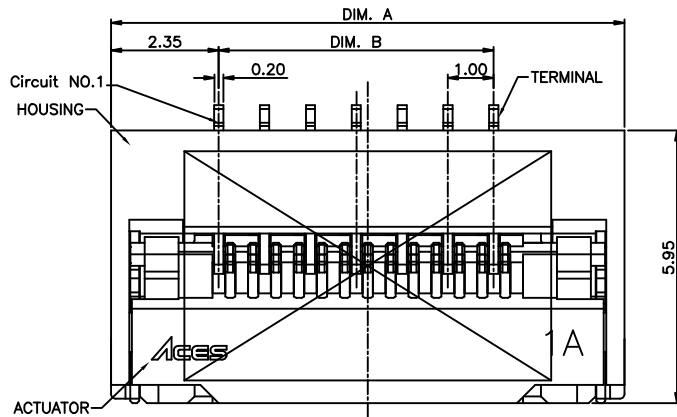

CKT	DIM A	DIM B	DIM C
25	29.30	24.00	25.56
30	34.30	29.00	30.56

QUALITY SYMBOLS MAJOR Ⓢ CRITICAL Ⓢ	DRAWN BY Sun,Ya Jie	DATE 23/10/30	
GENERAL TOLERANCES (UNLESS SPECIFIED)	CHECKED BY Xu,Zhi Yong	DATE 23/10/30	
X. ±0.5 .X ±0.25 .XX ±0.15 .XXX ±0.1 ANGLES ±2°	APPROVED BY Xu,Zhi Yong	DATE 23/10/30	TITLE 1.0mm PITCH EASY ON FPC/FFC CONN.
	UNITS mm	SCALE 8:1	SIZE A4
	SHEET NO. 1 OF 1	REV	RFG NO. N/A
			DWG NO. 50692-XXXX-001